

Question:

Ever have a shrink-wrapping project that your automatic or semi-automatic L-sealer couldn't handle due to size capacity or speed?

INTRODUCING A MARVEL IN SHRINK WRAPPING EQUIPMENT



Engineered Packaging Systems, Inc. would like to invite you to take a look at a new design in shrink wrapping machinery from Conflex®.

This *Made in the USA* machine is designed to replace the automatic L-sealer systems with a more logical, flexible design, which enables users a much broader range of package size capacity and speed.

CONTINUOUS SIDE SEAL TECHNOLOGY

If you are running an automatic L-sealing system, such as a Texwrap or Shanklin, this machine will eliminate the front sealing bar system and be replaced with a "side sealing" technology capable of running most polyolefin shrink film products. *Length of product is virtually NO ISSUE.*

SMALL OPERATING FOOTPRINT WITH HIGHER SPEEDS

This machine has the ability to fit into tight spaces in printing, fulfillment and contract packaging operations with its unique footprint of 79" Long x 58" Wide! *Large size capacity, small footprint. No machine like it. Film speeds up to 100 feet per minute! Which means, more productivity or more packages per minute!*

TALL AND LONGER PRODUCT CAPACITY

An excellent feature of this machine is its ability to wrap products as short as 2" Long to Unlimited Length (side sealer)! Additionally, the *height capacity is up to 10" High!* Got a small widget to run in the morning and a huge gadget in the afternoon? This machine can handle it with minimal changeover time!

PRICED AT OR BELOW AUTOMATIC L-SEALING SYSTEMS

This machine comes with everything you need with the support and services of Engineered Packaging Systems. Our training and installation services will have you running in no time. Our experienced staff will provide you with a full-service program that is unmatched by any other company.

HOW DO YOU GET A QUOTE ON THIS MACHINE AND FREE VIDEO?

EPS will provide to you a written proposal, along with our startup and training programs to include our shrink films programs. Additionally, you can call or email us for a FREE VIDEO of this machine!

Call **636-227-8600** (ask for John or Thom)

Email: info@engineeredpackagingsystems.com

FUSION Series

Intermittent Motion Side Seal Wrapper

Fusing Tomorrow's Shrink Packaging Requirements on Today's Budget



Conflex® ...Flexible People Make Flexible Systems

- **Faster than traditional auto L-sealers**—up to 100 feet per minute
- **Large Product Size Capacity and Flexibility**—Expanded sealing capacity for larger package sizes
- **Value Priced at or below traditional auto L-Sealers**—Operates faster than automatic L-bar sealers and requires less film
- **Safe**—Infeed and seal area guard covers provide safety and easy operator access
- **Compact Footprint**—Allows the machine to fit most packaging environment
- **Tool-less Changeover**—Crank adjustments provide easy, tool-less package size changeovers.
- **Variety of Shrink Tunnel Solutions** —EPS offers a wide range of shrink tunnels for specific applications

Con flex® ...Flexible People make Flexible Systems

Engineered for maximum flexibility, reliability and performance. Con flex® shrink packaging equipment incorporates leading-edge technology to take on the toughest shrink packaging challenges.

Value Priced—Versatile and Flexible

The Con flex® FUSION is setting the new industry standard as the machine of choice for entry-level wrappers. The value price and flexibility of options make it the perfect choice for automatic applications. By fusing the technology and economies of side sealing with the financial commitment of an automatic L-bar sealer, Con flex® makes the FUSION the smart choice to fill your shrink wrapping needs.

Con flex® FUSION Features and Benefits

- **Color HMI Touch Screen**—Provides intuitive, operator-friendly product setups in three languages
- **Easy Load Film Cradle**—The fast threading process makes changeovers more efficient
- **Self-Tracking Belts**—Eliminate tracking issues and reduces maintenance
- **Open Access/Swing-Out Inverting Head**—Allows fast film threading
- **Large Film Selvage Cone**—Can hold two rolls of film scrap, reducing costly downtime
- **Mushroom Style Cross Seal**—Provides positive hot knife sealing
- **Universal Side Sealer**—Runs a variety of films
- **Casters and Leg Levelers**—Standard equipment
- **Multiple Options Available**—Left-to-right product flow, stainless steel and other customizable options available

Con flex® FUSION Series Specifications

| | |
|----------------------------|---|
| Electrical Requirements | 220V, 20 Amps, 1 Phase |
| Air Requirements | 80 psi, 1 cfm |
| Seal Bar Width and Height | 24" wide, 10.5" high |
| Maximum Film Width | 32" |
| Maximum Roll Diameter | 14" |
| Overall Machine Dimensions | 79" L x 57.5" W x 59.5" H |
| Maximum Operating Speeds | 100' film per minute |
| Deck Height on Casters | 32" |
| Package Dimensions* | 2" L to unlimited L 1" W to 23" W** 1/8" H to 10" H |

*May require additional components and set-up time to run the entire size range.
**Product dependent.

Con flex® FUSION Series Plan View

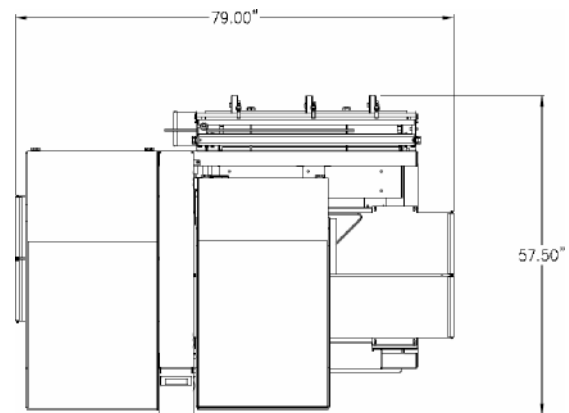

The Con flex® engineering department is available to customize machinery for special product applications.

Sold, installed and locally serviced by:



Engineered Packaging Systems, Inc.
16141 Westwoods Business Park
Ellisville, MO 63021
636.227.8600 (f)636.227.8601
info@engineeredpackagingsystems.com
www.engineeredpackagingsystems.com

Shop **EPS** online for 10,000 packaging items!
www.packeps.com

